

SPECIAL PROJECT AWARDS NOMINATION FORM

Deadline: Submit by September 2, 2009

Name of Community or Multi-Community: City of South Sioux City Population: 11,925

Name of Project: Roth Industrial Park

Project Contact Person: Dan McNamara

Phone: (402) 412-2507 Eve Phone: (712) 204-1990 E-mail: dmcnamara@southsiouxcity.org

Category: Economic Development Subcategory: Business Assistance and Development

Project Started (mo./yr.) 06/2006 Date Completed (mo./yr.) 08/2009

Project Annual/Ongoing? Yes No

Volunteer Hours 700 Number of Volunteers 27

1) Please provide a brief description of the project.

The South Sioux City Community Development Agency (CDA) and the City of South Sioux City recognized a need for additional quality jobs and an expanded tax base for the community. Roth Industrial Park was established with the purpose of creating a regional food cluster. This allowed the city to focus advertising, to attract value-added agriculture industries.

Comprised of over 600 acres of ground optioned or purchased outright by the CDA, the city needed to expand the infrastructure of water, sewer, electric and fiber optics to service future industries. Area economic development agencies, such as SIMPCO, Siouxland Initiative, South Sioux City Chamber, and the Siouxland Economic Development Corporation, worked together with the City of South Sioux City to make Roth Industrial Park a reality.

On December 19, 2006 Beef Products Incorporated (BPI) announced plans for the first Roth Industrial Park project, an unprecedented \$400 million expansion, projected to create 350 new jobs. Later that month Green Planet Farms announced plans to develop a new \$30 million dollar



facility within the Roth Industrial Park, creating 60 new jobs. In 2008, Peerless Energy, Omega Industries, Midco, Natural Innovative Renewable Energy (NIRE) and 21st Century Grain all announced plans to bring their industry to South Sioux City's Roth Industrial Park, bringing with them over \$150 million in private sector investments and more than 70 new jobs.

Due in part to the success of the Roth Industrial Park, Nebraska's Governor Dave Heinemann declared South Sioux City as the "Economic Capital of Nebraska".

2) Identify the planning and implementation of the project.

When the idea of Roth Industrial Park was introduced, it was seen as a way to attract new employers and increase the number of higher paying jobs. Local Economic Development agencies began working together. The South Sioux City Community Development Agency purchased and optioned land in the designated area, while the city staff sought out funding the Nebraska Department of Economic Development (DED) and the Economic Development Administration (EDA).



Since the proposed site for Roth Industrial Park included some ground that was located outside South Sioux City limits, an interlocal agreement was made with encompassing Dakota County and bordering Dakota City. The City of South Sioux City entered into an agreement with Dakota County, that if a new facility was built on the Dakota County side, South Sioux City would receive the first year's property tax. The agreement with Dakota City stated that if a new facility was built in Dakota City limits, South Sioux City would provide the utility

services to support the industry. In turn Dakota City and South Sioux City would split the property tax regardless of whether or not it is annexed by either party.

Once the agreements were in place and acquisitions had been completed, the City of South Sioux City began working towards its goal to upgrade and expand the infrastructure of the water, sewer and fiber optic services to meet the needs of potential industries, allowing for shovel ready sites. Nebraska Public Power District (NPPD) also jumped on board, not only through capacity expansion for electrical service, but also through marketing and trade shows.

Since Roth Industrial Park was going to be a regional food cluster, NPPD along with the Siouxland Initiative and the State of Nebraska began marketing, to target food based industries. SIMPCO created a Comprehensive Economic Development Strategy that focused on food clustering and value-added agriculture. The Siouxland Initiative, along with CDA, worked to achieve Site Certification through McCallum Sweeney Consulting. New advertisements were created for radio and television; in addition, through internet advertising, including the city website, www.southsiouxcity.org, and podcasts, the information was able to reach beyond the local community.



3) Describe volunteer involvement in planning and implementing the project.

Volunteers worked through different Economic Development agencies to accomplish the following:

Community Development Agency

Land Option and Land Acquisition
 Site Certification by McCallum Sweeney
 Marketing

City of South Sioux City

Upgrade and Expansion of Water, Sewer & Fiber
 Obtaining DED and EDA Funding
 Agreements with Dakota City and Dakota County

Nebraska Public Power District

Electric Service and Capacity Expansion
 Marketing

Siouxland Initiative-

Site Certification by McCallum Sweeney
 Marketing

SIMPCO

Comprehensive Economic Development Strategy

4) Identify Project Outcomes.

The South Sioux City Community Development Agency (CDA) and the City of South Sioux City recognized a need for additional quality jobs and an expanded tax base for the community. Roth Industrial Park was established to meet those needs. Area economic development agencies, such as the Community Development Agency, NPPD, SIMPCO, Siouxland Initiative, South Sioux City Chamber, and the Siouxland Economic Development Corporation, came together with the City of South Sioux City in full support of making Roth Industrial Park a reality.



The following chart shows a break down of the private sector investment and job creation that is a direct result of Roth Industrial Park.

<u>Year</u>	<u>Company</u>	<u>Jobs</u>	<u>Investment</u>
2006	BPI	350	\$430 million
2006	Green Planet Farms	60	\$ 30 million
2008	Omega Industries	15	\$ 3 million
2008	Peerless Energy	10	\$ 3 million
2008	21 st Century Grain	3	\$ 10 million
2008	NIRE	35	\$130 million
2008	Midco	10	\$ 1.5 million
TOTAL		483	\$607.5 million





In addition, local contractors were used for the construction of the existing Roth Industrial Park facilities.

As Roth Industrial Park continues to expand, the City of South Sioux City is actively seeking land options surrounding the park, for future growth. Utilities are in place to support future expansion and NPPD is planning to build a \$34 million sub station and transition station adjacent to the park.

5) Describe how resources were identified and used to successfully implement the project.

Resource	Amount	Used For
EDA Funds	\$2 million	Infrastructure
Tax Increment Financing (On southern portion of park)	\$2 million	Acquisition of land, paving entrance roads and extending utilities to site at no cost to industries.
State Revolving Funds	\$1.9 million	Sewer lines and lift station
City of South Sioux City	\$100,000	Expansion of the city’s fiber optic ring
	\$5.3 million	New electric sub station
CDA	\$1.3 million	Land purchase
CDBG	\$ 1 million	Development of projects in Roth Industrial Park

Local contractors were hired by the industry to construct their facility in Roth Industrial Park.

6) What aspects (if any) of the project were especially unique or creative? Please describe.

As previously mentioned, Roth Industrial Park includes some ground that is located outside of South Sioux City limits, which made way for interlocal agreements to be made with Dakota County and the City of Dakota City. The City of South Sioux City entered into an agreement with Dakota County, that if a new facility is built on the Dakota County side, South Sioux City will receive the first year’s property tax. The agreement with Dakota City states that if a new facility is built in Dakota City limits, South Sioux City will provide the utility services to support the industry. In turn Dakota City and South Sioux City would split the property tax regardless of whether or not it is annexed by either party.

Applications are pending for Roth Industrial Park to become Nebraska’s first geothermal park. This addition would allow BPI to circulate approximately 9 million gallons of water per day throughout the industrial park, for other industries to use as a resource for heat and a portion would become potable city water.

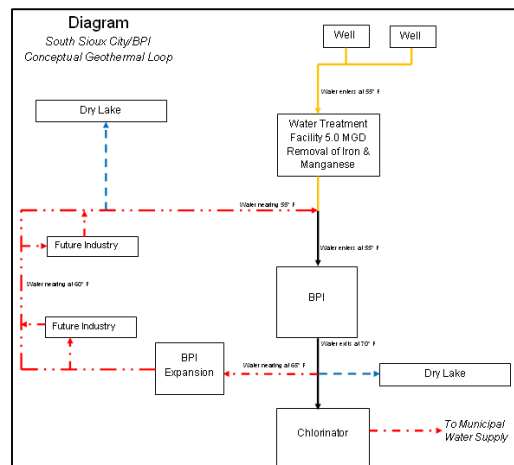

Sioux City Again Claims Tier 3 Crown

There's perhaps no better evidence of community support for economic development than when diverse interests band together to support the common good.

That's exactly what happened last year when four companies decided to postpone their respective expansion announcements so that Nebraska Gov. Dave Heineman could be on hand to deliver the good news.

Executives of **Peerless Energy**, **Omega Industries**, **21st Century Grain** and **National Innovative Renewable Energy (NIRE)** all came together at the Roth Industrial Park in South Sioux City, Neb., to watch the governor announce their plans to build new facilities.

Those projects were four of the 20 expansion deals that propelled the tri-state area of Sioux City, Iowa-Neb.-S.D., to the No. 1 ranking among all U.S. metropolitan areas of less than 200,000 in population.

Claiming its second consecutive win in the tier-three category of communities, Sioux City doubled the output of its closest competition –runner-up Springfield, Ohio, which had 10 corporate real estate deals in 2008.

"When the governor came to make these project announcements, he said that South Sioux City is the economic development capital of the state of Nebraska right now," says Chris McGowan, executive vice president of economic development for the Siouland Initiative. "We even kicked off that day in July with a ribbon-cutting at **Green Planet Farms**, a \$40-million organic soybean processing plant located in the Roth Industrial Park. We went from that event to a groundbreaking for all these other projects."

McGowan says that spirit of teamwork is not an aberration in the Siouland region.

"Every state and every community in our area had at least one project represented in our total of 20," he says. "All communities in the region contributed to this victory. That is really a huge part of the reason that we have been successful. We have three different state economic development incentive packages to present to prospects whenever they are considering our area, and that is a huge advantage."

"For the past decade, we have been propelling our strategic vision for economic growth," says Debi Durham, president of both the Siouland Initiative and the Siouland Chamber of Commerce. "We made sure we had land sites that were both developed and certified. We made sure we had industrial parks and infrastructure. And we have been strategic in our marketing efforts."

Durham says it's also crucial "that we understand who we are. Food processing is our foundation, and we have learned to play to that strength."

In recent years, the area has also attracted large investments in bio-fuels, wind energy, data centers and customer contact centers. In 2008, seven area projects were either data centers or call centers.

The NIRE project could end up being one of the most significant deals ever for the Sioux City metro area. The \$130-million bio-diesel plant is expected to generate 35 to 40 new jobs and contribute 60 million gallons of the alternative fuel each year. "

— Ron Starner

Source: Site Selection Magazine, March 2009 (www.siteselection.com/issues/2009/mar/Top-Metros/)